

2

KLIZAČI

KLIZAČI

2.1 BLUM TANDEMI	56
TANDEM BLUMOTION DELIMIČNA IZVLAKA	56
TANDEM TIP ON DELIMIČNA IZVLAKA	57
TANDEM BLUMOTION POTPUNA IZVLAKA	59
TANDEM TIP ON POTPUNA IZVLAKA	60
2.2 BLUM MOVENTO	62
MOVENTO BLUMOTION	62
MOVENTO TIP ON BLUMOTION	63
2.3 BLUM PODNI KLIZAČ	65
2.4 BLUM KLIZAČ ZA RADNE POVRŠINE	66
2.5 EMUCA SKRIVENI KLIZAČI	67
EMUCA SKRIVENI KLIZAČI DELIMIČNA IZVLAKA SLOW	67
EMUCA SKRIVENI KLIZAČI DELIMIČNA IZVLAKA TIP ON	68
EMUCA SKRIVENI KLIZAČI POTPUNA IZVLAKA SLOW	69
EMUCA SKRIVENI KLIZAČI POTPUNA IZVLAKA TIP ON	70
EMUCA SILVER KLIZAČI DELIMIČNA IZVLAKA	71
2.6 STANDARDNI KLIZAČI	72
2.7 TELESKOPI I MIKROKLIZAČI	73

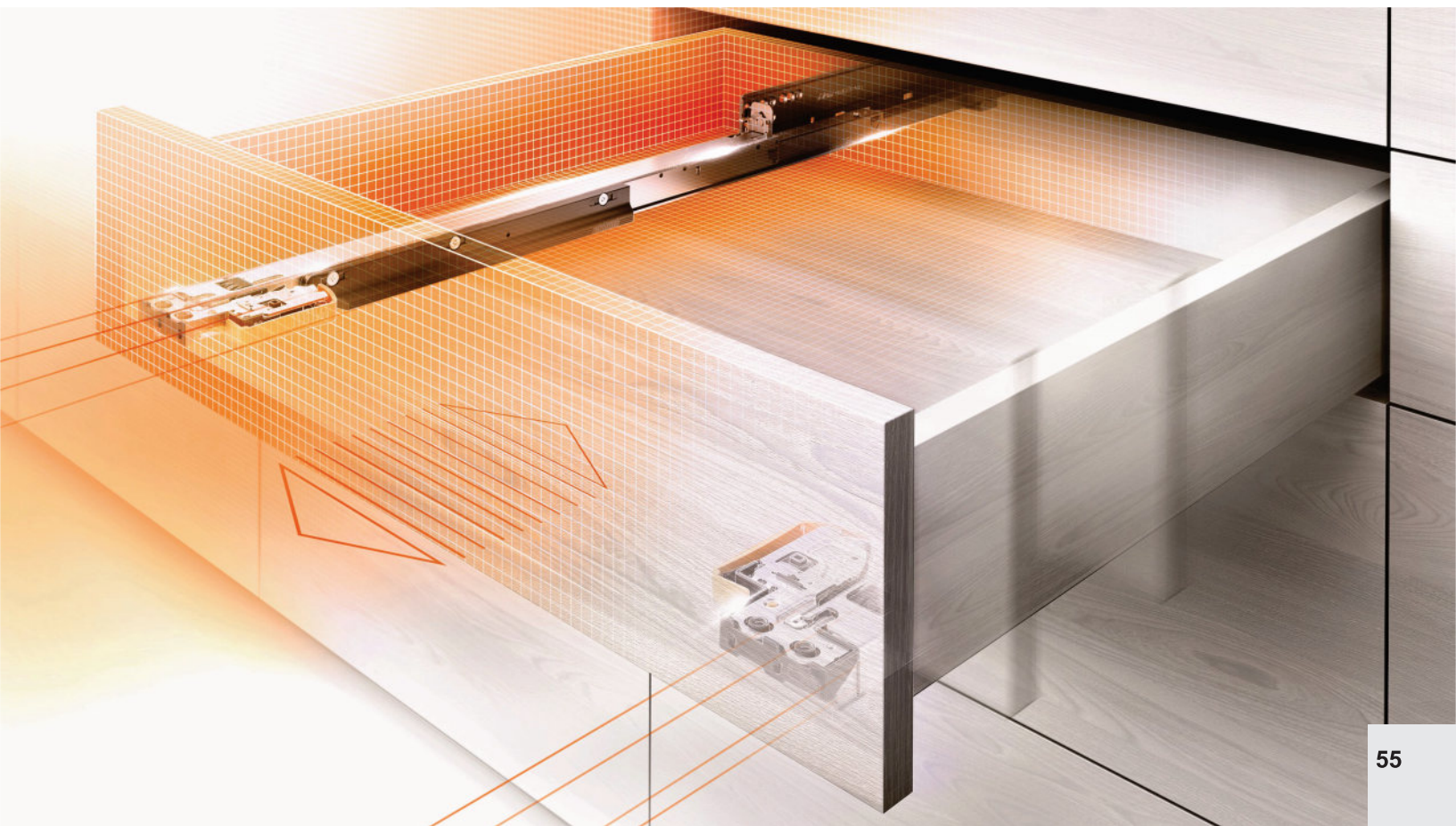

BLUM

TANDEM BLUMOTION DELIMIČNA IZVLAKA

PROIZVOD

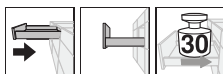
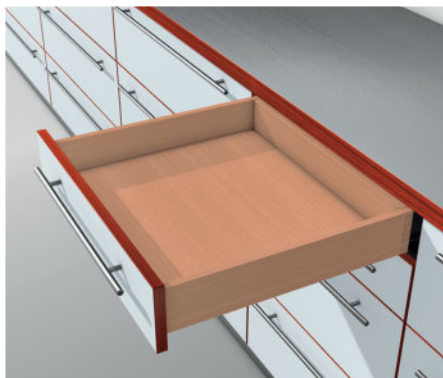

OPIS

- Skriveni tandem delimična izvlaka sa integrisanim BLUMOTION za lako i tiho zatvaranje
- TANDEM inside – za izrazito lagan hod dokle god traje nameštaj
- Podešavanje visine spojnice bez alata
- Izjednačavanje tolerancije bočno i po dubini
- Opciono SERVO-DRIVE

POTREBAN PROSTOR

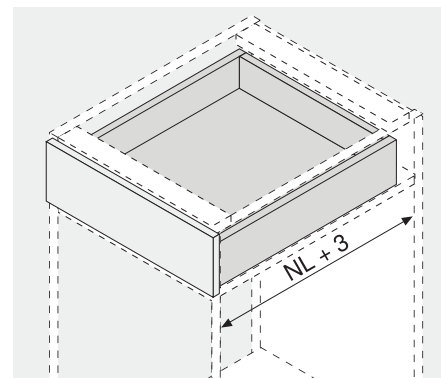

NL Nominalna dužina

1. KLIZAČI TANDEM DELIM.IZVL.+ BLUMOTION



Naziv artikla	Šifra
TANDEM DELIMIČNA IZVLAKA 270	B-550H2700B
TANDEM DELIMIČNA IZVLAKA 300	B-550H3000B
TANDEM DELIMIČNA IZVLAKA 350	B-550H3500B
TANDEM DELIMIČNA IZVLAKA 400	B-550H4000B
TANDEM DELIMIČNA IZVLAKA 450	B-550H4500B
TANDEM DELIMIČNA IZVLAKA 500	B-550H5000B
TANDEM DELIMIČNA IZVLAKA 550	B-550H5500B
TANDEM DELIMIČNA IZVLAKA 600	B-550H6000B
TANDEM DELIMIČNA IZVLAKA 650	B-550H6500B

2. SPOJKE ZA TANDEM KLIZAČE



Naziv artikla	Šifra
SPOJKA ZA TANDEM DESNA	B-T51.1700.04R
SPOJKA ZA TANDEM LEVA	B-T51.1700.04L

Fioka

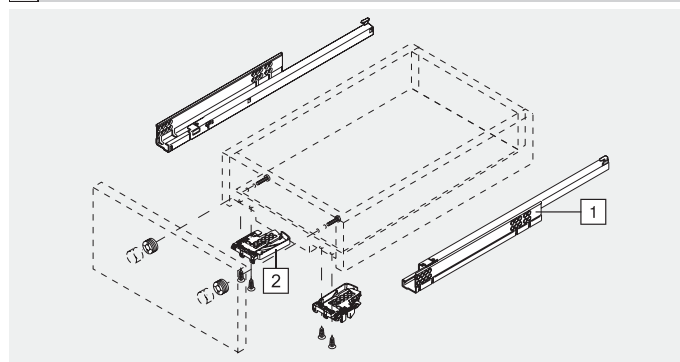

Pozicija za zavrtanje (Nominalna dužina NL)

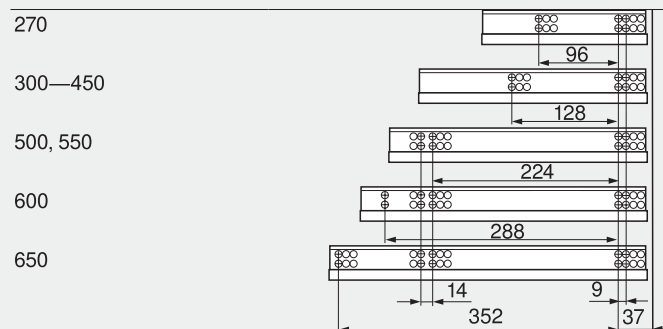

Planiranje

Potreban prostor u korpusu

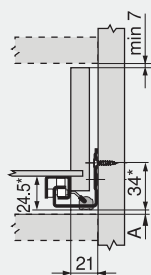

Fioke/unutrašnje fioke

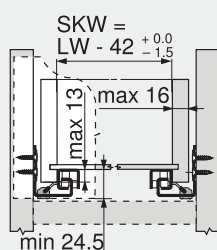

SKW Unutrašnja širina fioke
LW Unutrašnja širina korpusa

Fioka

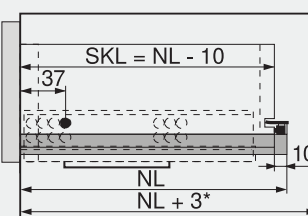

SKL Dužina fioke
NL Nominalna dužina

Unutrašnja fioka

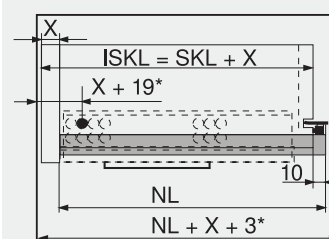

ISKL Unutrašnja dužina fioke
SKL Dužina fioke
NL Nominalna dužina

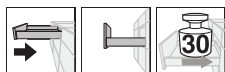
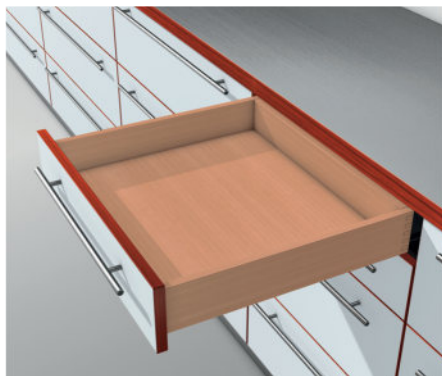
TANDEM TIP ON DELIMIČNA IZVLAKA
PROIZVOD

OPIS

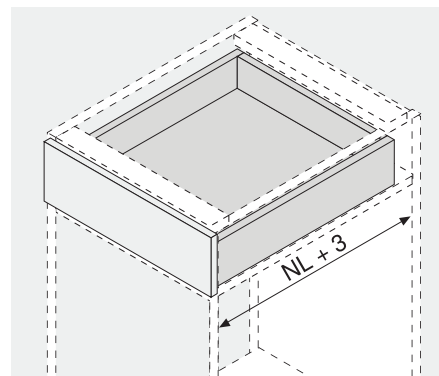
- Skriveni tandem delimična izvlaka sa TIP ON mehanizmom
- TANDEM inside – za izrazito lagan hod dokle god traje nameštaj
- Podešavanje visine spojnice bez alata
- Izjednačavanje tolerancije bočno i po dubini
- TIP ON sinhronizacija za sigurno aktiviranje i kod veoma širokih frontova (NL>600).

POTREBAN PROSTOR

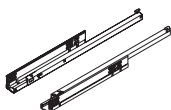
NL Nominalna dužina

1. KLIZAČI TANDEM TIP ON DELIMIČNA IZVLAKA

Naziv artikla	Šifra
TANDEM TIP ON DEL. IZVLAKA 270	B-550H2700.03
TANDEM TIP ON DEL. IZVLAKA 300	B-550H3000.03
TANDEM TIP ON DEL. IZVLAKA 350	B-550H3500.03
TANDEM TIP ON DEL. IZVLAKA 400	B-550H4000.03
TANDEM TIP ON DEL. IZVLAKA 450	B-550H4500.03
TANDEM TIP ON DEL. IZVLAKA 500	B-550H5000.03
TANDEM TIP ON DEL. IZVLAKA 550	B-550H5500.03
TANDEM TIP ON DEL. IZVLAKA 600	B-550H6000.03

2. SPOJKE ZA TANDEM KLIZAČE

Naziv artikla	Šifra
SPOJKA ZA TANDEM DESNA	B-T51.1700.04R
SPOJKA ZA TANDEM LEVA	B-T51.1700.04L

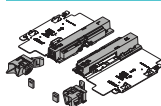
3. TIP ON MEHANIZAM

Naziv artikla	Šifra
TIP-ON T55.1150S	B-T55.1150S

NAPOMENA: Za širinu fioke veću od 600mm potrebno je dodati sinhronizaciju (stavke 4 i 5).

4. TIP ON ZUPČANICI

Naziv artikla	Šifra
TIP-ON KPL.ZUPČANIKA	B-T55.000R

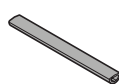
5. OSOVINA ZA SINHRONIZACIJU

Naziv artikla	Šifra
TIP-ON OSOVINA POLUKRUŽNA	B-T55.889W

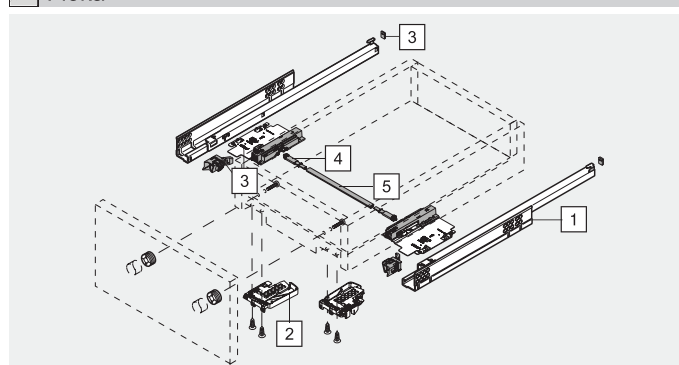
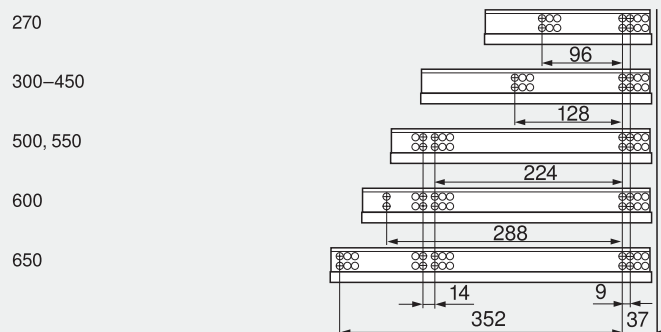
Fioka

Pozicija za zavrtanje (Nominalna dužina NL)

TANDEM TIP ON DELIMIČNA IZVLAKA

Planiranje

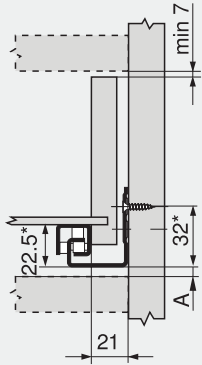
Potreban prostor u korpusu



Fioke/unutrašnje fioke

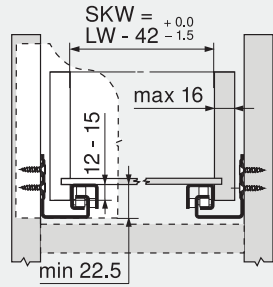

SKW Unutrašnja širina fioke
LW Unutrašnja širina korpusa

Fioka

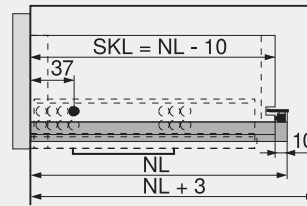

SKL Dužina fioke
NL Nominalna dužina

Unutrašnja fioka

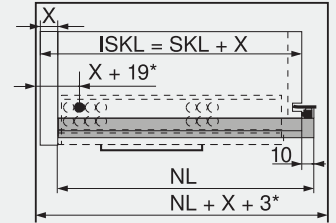

ISKL Unutrašnja dužina fioke
SKL Dužina fioke
NL Nominalna dužina

Montaža spojki

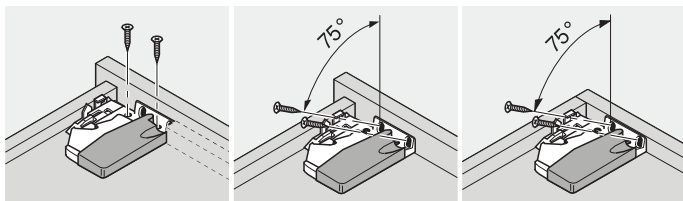

Podešavanje spojki

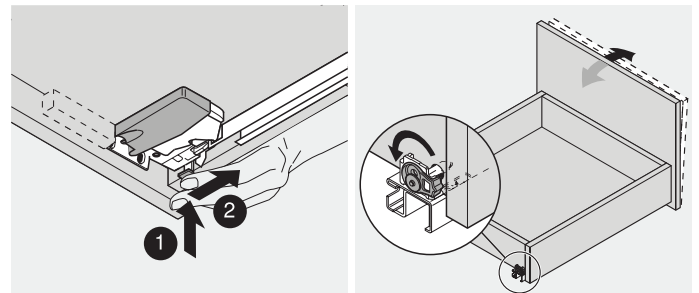

Podešavanje visine
+3 mm

Podešavanje nagiba preko vodice

Montaža i demontaža fioke

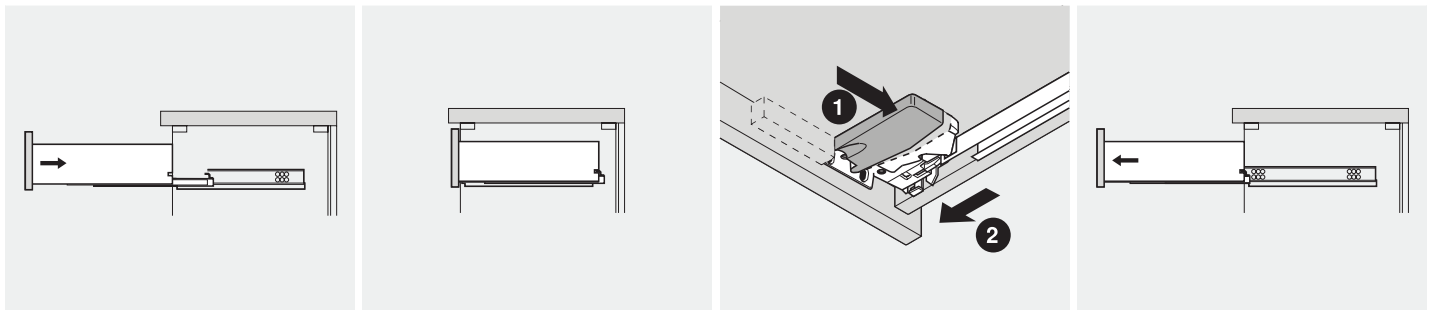

Kačenje

Skidanje

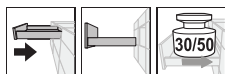
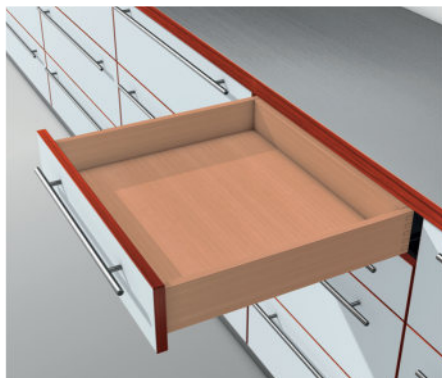
TANDEM BLUMOTION POTPUNA IZVLAKA
PROIZVOD

OPIS

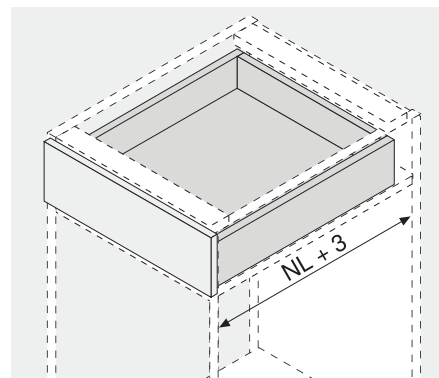
- Skriveni tandem potpuna izvlaka sa integrisanim BLUMOTION za lako i tiho zatvaranje
- TANDEM inside – za izrazito lagan hod dokle god traje nameštaj
- Podešavanje visine spojnice bez alata
- Izjednačavanje tolerancije bočno i po dubini
- Opciono SERVO-DRIVE

POTREBAN PROSTOR

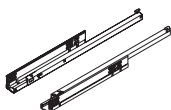
NL Nominalna dužina

1. KLIZAČI TANDEM POTPUNA IZVL.+ BLUMOTION

Naziv artikla	Šifra
TANDEM POTPUNA IZVLAKA 250	B-560H2500B
TANDEM POTPUNA IZVLAKA 300	B-560H3000B
TANDEM POTPUNA IZVLAKA 350	B-560H3500B
TANDEM POTPUNA IZVLAKA 400	B-560H4000B
TANDEM POTPUNA IZVLAKA 450	B-560H4500B
TANDEM POTPUNA IZVLAKA 500	B-560H5000B
TANDEM POTPUNA IZVLAKA 550	B-560H5500B
TANDEM POTPUNA IZVLAKA 600	B-560H6000B
TANDEM POTPUNA IZVL. 500-50kg	B-566H5000B

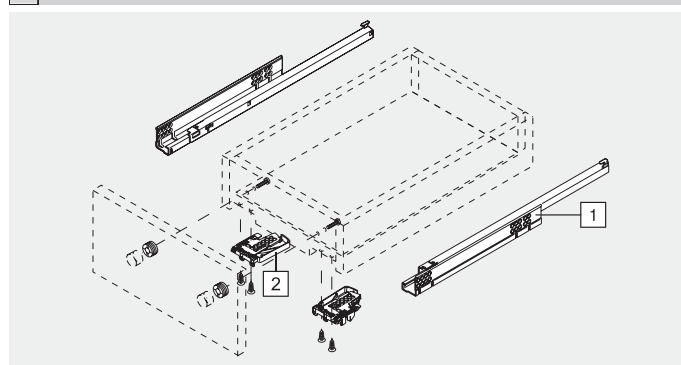
Fioka

Pozicija za zavrtnje (Nominalna dužina NL)

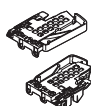
250	
300	
350	
400	
450	
500—550	
600	

2. SPOJKE ZA TANDEM KLIZAČE

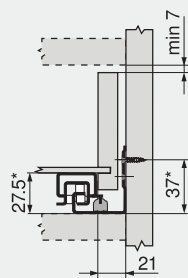
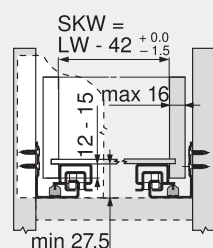
Naziv artikla	Šifra
SPOJKA ZA TANDEM DESNA	B-T51.1700.04R
SPOJKA ZA TANDEM LEVA	B-T51.1700.04L

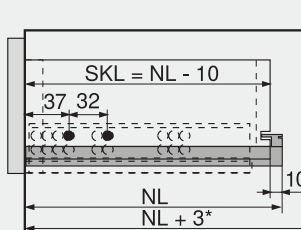
Planiranje
Potreban prostor u korpusu

Fioke/unutrašnje fioke

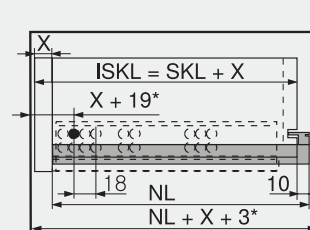
 SKW Unutrašnja širina fioke
 LW Unutrašnja širina korpusa

Fioka

 SKL Dužina fioke
 NL Nominalna dužina

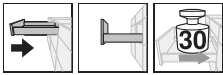
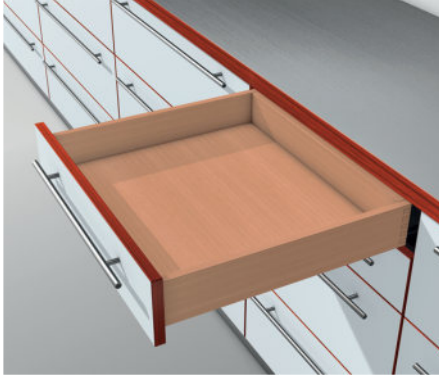
Unutrašnja fioka

 ISKL Unutrašnja dužina fioke
 SKL Dužina fioke
 NL Nominalna dužina

TANDEM TIP ON POTPUNA IZVLAKA

PROIZVOD



OPIS

- Skriveni tandem potpuna izvlaka sa TIP ON mehanizmom
- TANDEM inside – za izrazito lagan hod dokle god traje nameštaj
- Podešavanje visine spojnice bez alata
- Izjednačavanje tolerancije bočno i po dubini
- TIP ON sinhronizacija za sigurno aktiviranje i kod veoma širokih frontova (NL>600).

POTREBAN PROSTOR

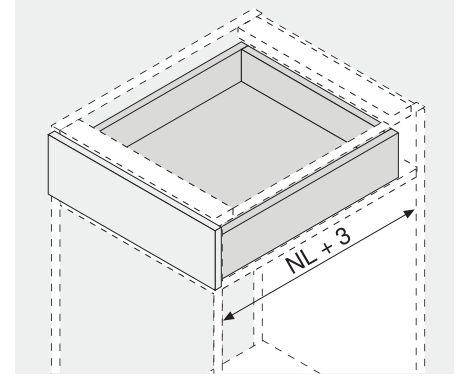

NL Nominalna dužina

1. KLIZAČI TANDEM TIP ON POTPUNA IZVLAKA

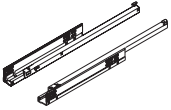

Naziv artikla	Šifra
TANDEM TIP ON POT. IZVLAKA 250	B-560H2500C
TANDEM TIP ON POT. IZVLAKA 300	B-560H3000C
TANDEM TIP ON POT. IZVLAKA 350	B-560H3500C
TANDEM TIP ON POT. IZVLAKA 400	B-560H4000C
TANDEM TIP ON POT. IZVLAKA 450	B-560H4500C
TANDEM TIP ON POT. IZVLAKA 500	B-560H5000C
TANDEM TIP ON POT. IZVLAKA 550	B-560H5500C
TANDEM TIP ON POT. IZVLAKA 600	B-560H6000C

2. SPOJKE ZA TANDEM KLIZAČE



Naziv artikla	Šifra
SPOJKA ZA TANDEM DESNA	B-T51.1700.04R
SPOJKA ZA TANDEM LEVA	B-T51.1700.04L

3. TIP ON MEHANIZAM

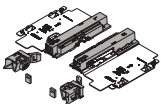

Naziv artikla	Šifra
TIP-ON T55.7150S	B-T55.7150S

NAPOMENA: Za širinu fioka veću od 600mm potrebno je dodati sinhronizaciju (stavke 4 i 5).

4. TIP ON ZUPČANICI



Naziv artikla	Šifra
TIP-ON KPL.ZUPČANIKA	B-T55.000R

Fioka

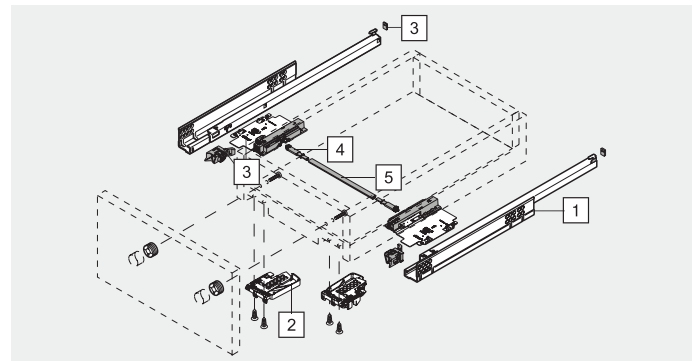

Pozicija za zavrtnje (Nominalna dužina NL)

250	
300	
350	
400	
450	
500—550	
600	

Dimensions: 14, 32, 9, 64, 224, 37, 96, 160, 64, 128

5. OSOVINA ZA SINHRONIZACIJU

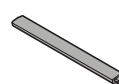

Naziv artikla	Šifra
TIP-ON OSOVINA POLUKRUŽNA	B-T55.889W

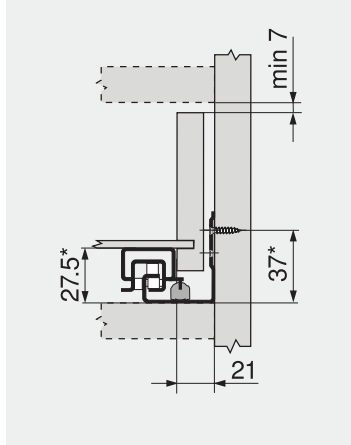
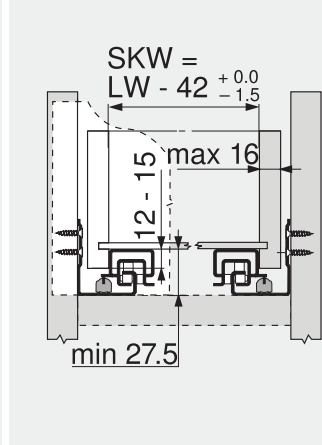
TANDEM TIP ON POTPUNA IZVLAKA
Planiranje
Potreban prostor u korpusu

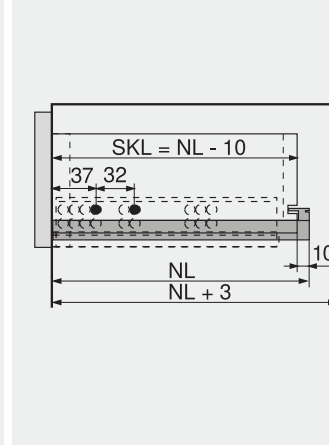
Fioke/unutrašnje fioke

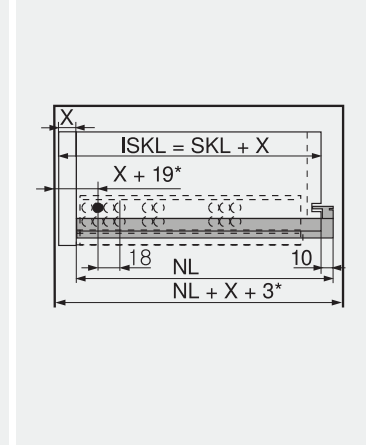
 SKW Unutrašnja širina fioke
 LW Unutrašnja širina korpusa

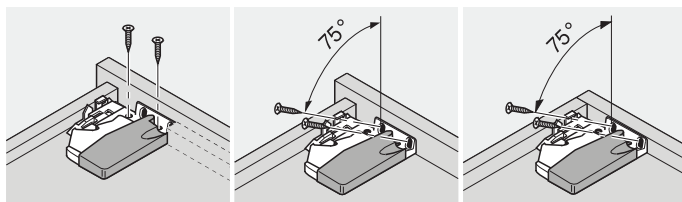
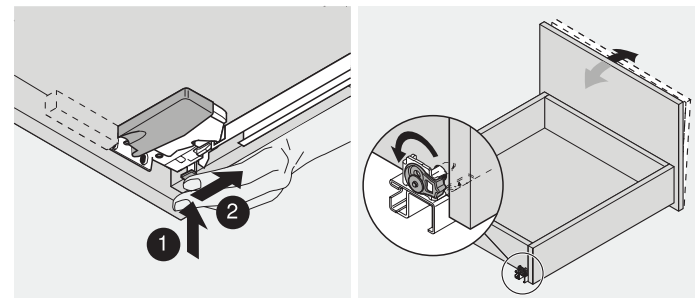
Fioka

 SKL Dužina fioke
 NL Nominalna dužina

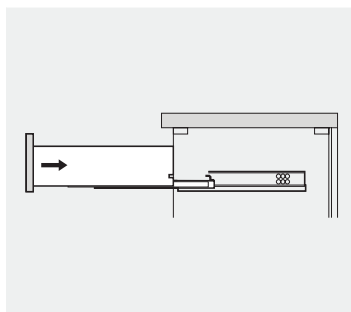
Unutrašnja fioka

 ISKL Unutrašnja dužina fioke
 SKL Dužina fioke
 NL Nominalna dužina

Montaža spojki

Podešavanje spojki

 Podešavanje visine
 +3 mm

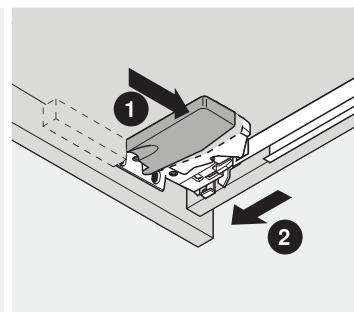
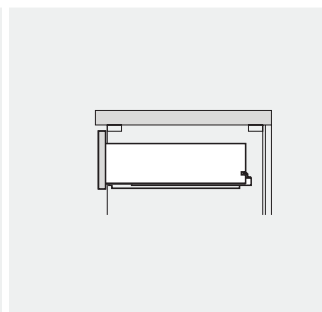
Podešavanje nagiba preko vodice

Montaža i demontaža fioke

Kačenje



Skidanje

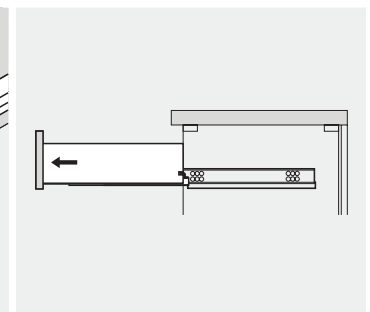

MOVENTO BLUMOTION

PROIZVOD

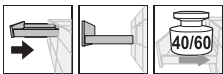

OPIS

- Skriveni klizač popuna izvlaka sa integrisanim BLUMOTION za lako i tiho zatvaranje
- Sinhronizovani lagani hod
- Podešavanje bočno, po visini i nagibu bez alata
- Podešavanje po dubini bez alata
- Izjednačavanje tolerancije bočno i po dubini
- Opciono SERVO-DRIVE

POTREBAN PROSTOR

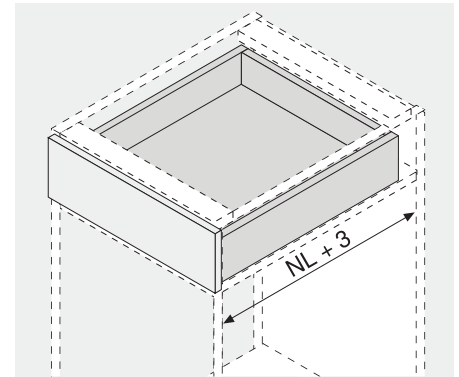

NL Nominalna dužina

1. KLIZAČI MOVENTO + BLUMOTION

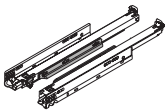

Naziv artikla	Šifra
MOVENTO KLIZAČ 760H3000	B-760H3000S
MOVENTO KLIZAČ 760H3500	B-760H3500S
MOVENTO KLIZAČ 760H4000	B-760H4000S
MOVENTO KLIZAČ 760H4500	B-760H4500S
MOVENTO KLIZAČ 760H5000	B-760H5000S
MOVENTO KLIZAČ 760H5500	B-760H5500S
MOVENTO KLIZAČ 766H5000-60KG	B-766H5000S
MOVENTO KLIZAČ 766H6000-60KG	B-766H6000S

2. SPOJKE ZA MOVENTO KLIZAČE

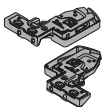

Naziv artikla	Šifra
SPOJKA ZA MOVENTO DESNA	B-T51.7601D
SPOJKA ZA MOVENTO LEVA	B-T51.7601L

Fioka

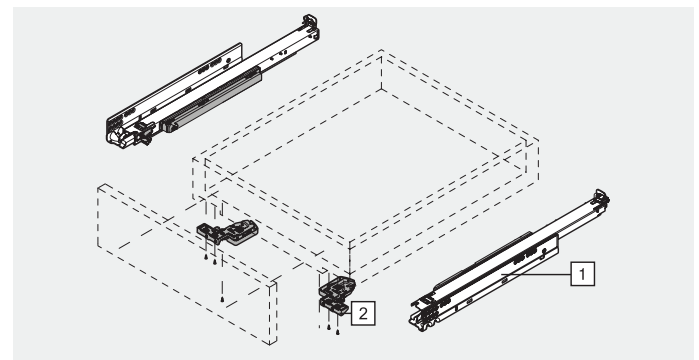

Pozicija za zavrtnje (Nominalna dužina NL)

Korpusna šina – 40 kg

300—350
380—520
550, 600

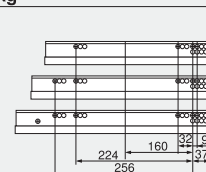

Korpusna šina – 60 kg

500—600

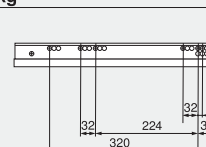

Planiranje

Potreban prostor u korpusu

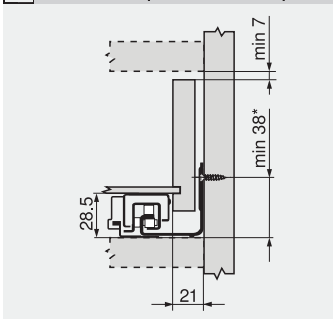

Fioke/unutrašnje fioke

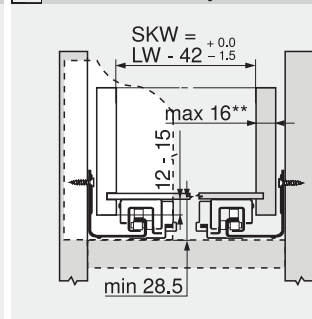

SKW Unutrašnja širina fioke
LW Unutrašnja širina korpusa

Fioka

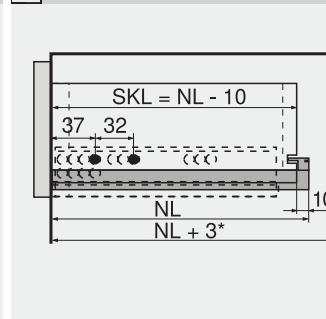

SKL Dužina fioke
NL Nominalna dužina

Unutrašnja fioka

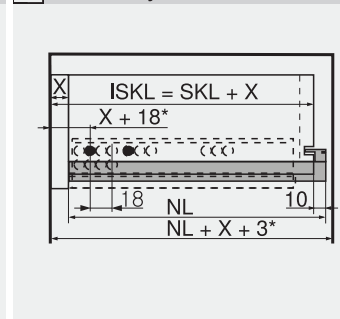

ISKL Unutrašnja dužina fioke
SKL Dužina fioke
NL Nominalna dužina

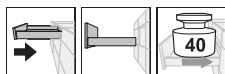
MOVENTO TIP ON BLUMOTION
PROIZVOD

OPIS

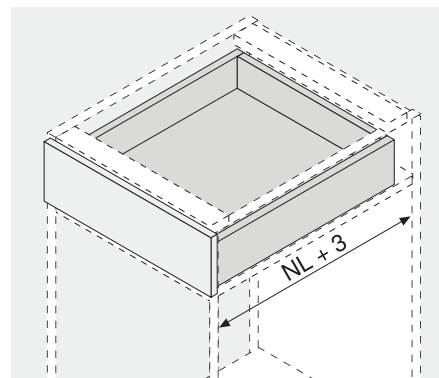
- Skriveni klizač sa kompletnim izvlačenjem
- Sinhronizovani lagani hod
- Podešavanje bočno, po visini i nagibu bez alata
- Integrisano podešavanje po dubini bez alata
- Izjednačavanje tolerancije bočno i po dubini
- Integrisani TIP-ON BLUMOTION mehanizam

POTREBAN PROSTOR

NL Nominalna dužina

1. KLIZAČI MOVENTO TIP-ON BLUMOTION

Naziv artikla	Šifra
MOVENTO TIP-ON BLU. 760H 3000S	B-760H3000S
MOVENTO TIP-ON BLU. 760H 3500S	B-760H3500S
MOVENTO TIP-ON BLU. 760H 4000S	B-760H4000S
MOVENTO TIP-ON BLU. 760H 4500S	B-760H4500S
MOVENTO TIP-ON BLU. 760H 5000S	B-760H5000S
MOVENTO TIP-ON BLU. 760H 5500S	B-760H5500S

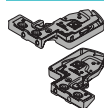
2. SPOJKE ZA MOVENTO TIP-ON BLU. KLIZAČE

Naziv artikla	Šifra
SPOJKA ZA MOVENTO DESNA	B-T51.7601D
SPOJKA ZA MOVENTO LEVA	B-T51.7601L

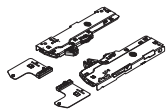
3. TIP ON BLUMOTION KOMPLET

Naziv artikla	Šifra
TIP-ON BLU. JEDI. I DRŽAČ (270-320)	B-T60L7140
TIP-ON BLU. JEDI. I DRŽAČ (350-600)	B-T60L7540

4. ADAPTER ZA SINHRONIZACIJU

Naziv artikla	Šifra
TIP-ON BLUMOTION ADAPTER	B-T60.000D

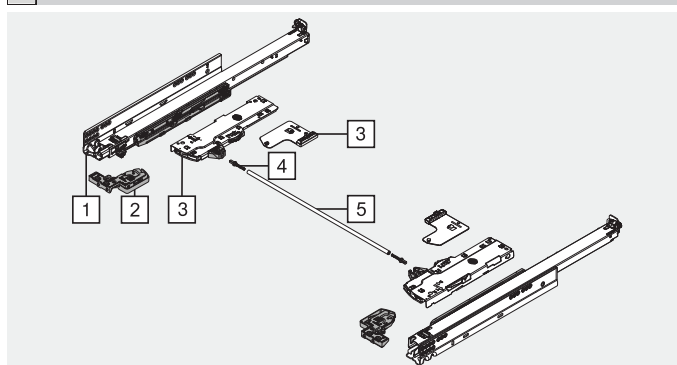
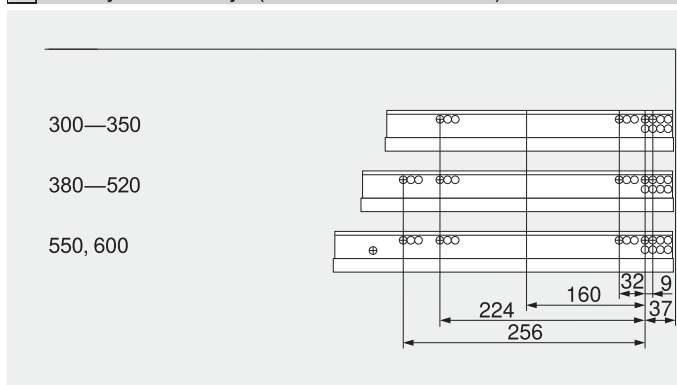
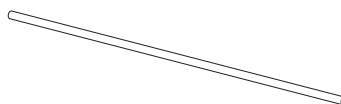
Fioka

Pozicija za zavrtnje (Nominalna dužina NL)

5. OSOVINA ZA SINHRONIZACIJU

Naziv artikla	Šifra
TIP-ON BLUMOTION OSOVINA	B-T60.1125W

MOVENTO TIP ON BLUMOTION

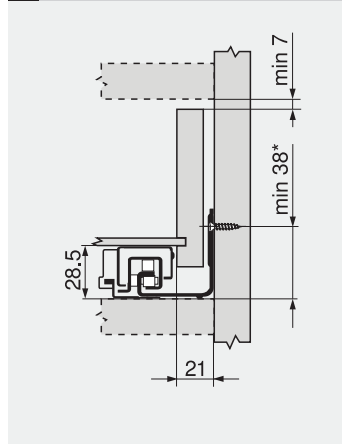
Planiranje

Potreban prostor u korpusu



Fioke/unutrašnje fioke

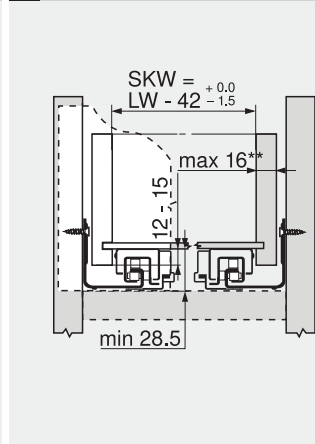

Fioka

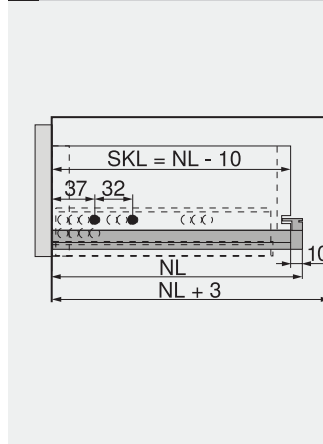

Unutrašnja fioka

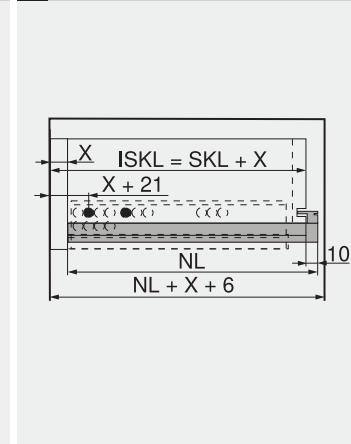

SKW Unutrašnja širina fioke
LW Unutrašnja širina korpusa

SKL Dužina fioke
NL Nominalna dužina

ISKL Unutrašnja dužina fioke
SKL Dužina fioke
NL Nominalna dužina

TIP-ON BLUMOTION

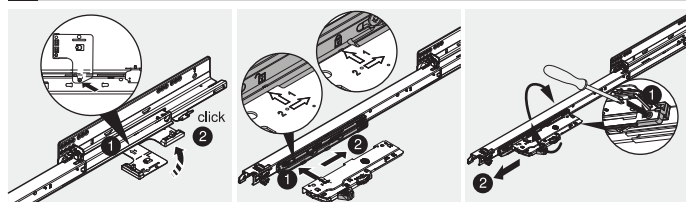

Podešavanje dubine – TIP-ON BLUMOTION

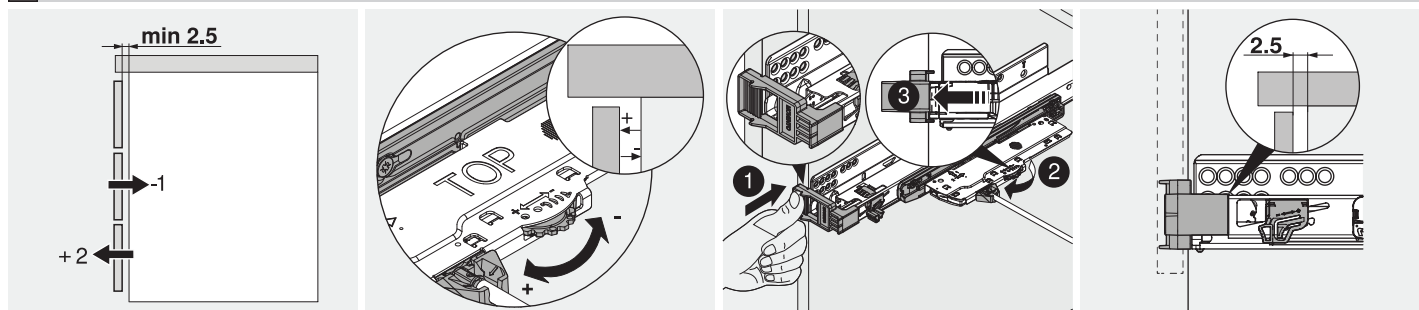

TIP-ON BLUMOTION-sinhronizacija

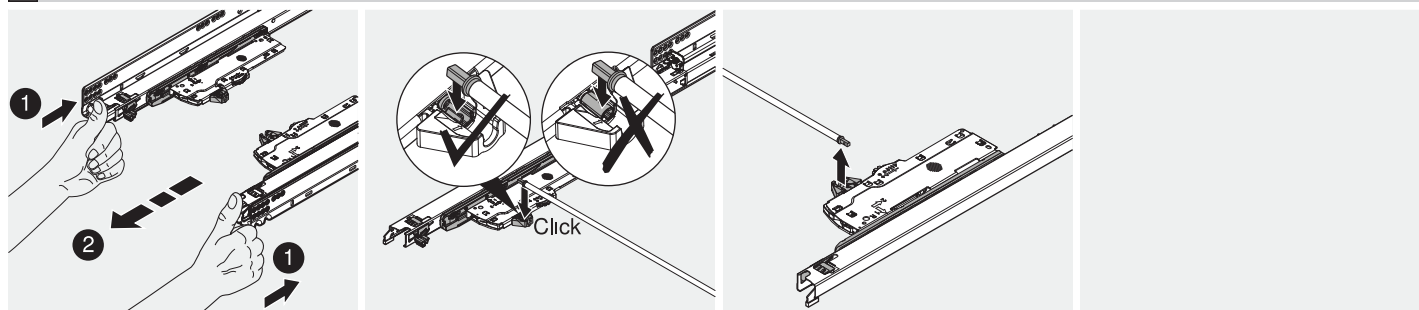

Montaža

Demontaža

BLUM PODNI KLIZAČ ZA POLICE I FIOKE
PROIZVOD

OPIS

- Skriveni klizač potpuno izvlačenje sa integrisanim BLUMOTION za lako i tiho zatvaranje
- Sinhronizovani lagani hod
- Podešavanje bez alata, bočno, po visini i nagibu
- Izjednačavanje tolerancije bočno i po dubini
- Podno kačenje klizača

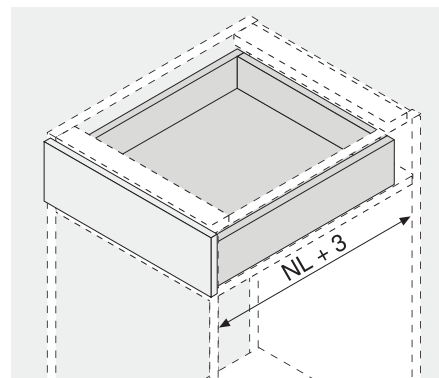
POTREBAN PROSTOR

NL Nominalna dužina

1. KLIZAČ MOVENTO PODNO KAČENJE

Naziv artikla	Šifra
KLIZAČ MOVENTO L-450	B-760H4500SU
KLIZAČ MOVENTO L-500	B-760H5000SU

2. SPOJKE ZA MOVENTO TIP-ON BLU. KLIZAČE

Naziv artikla	Šifra
SPOJKA ZA MOVENTO DESNA	B-T51.7601D
SPOJKA ZA MOVENTO LEVA	B-T51.7601L

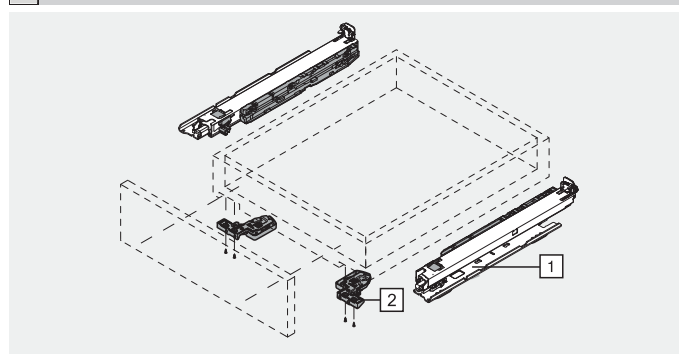
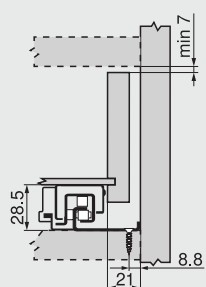
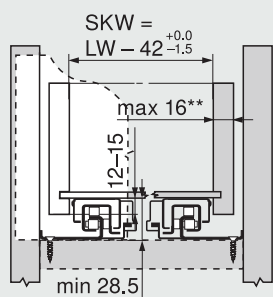
Fioka

Planiranje - fioka
Potreban prostor u korpusu

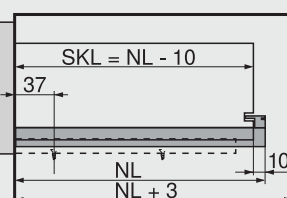
Fioke | unutrašnje fioke

SKW Unutrašnja širina fiok
LW Unutrašnja širina korpusa

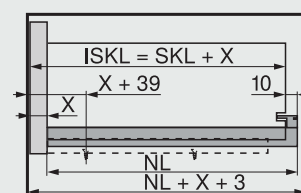
Fioka

SKL Dužina fiok
NL Nominalna dužina

Unutrašnja fioka

ISKL Unutrašnja dužina fiok
SKL Dužina fiok
NL Nominalna dužina
X Debljina fronta

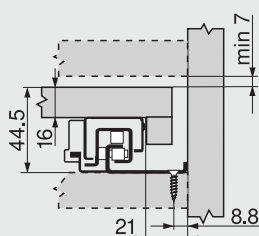
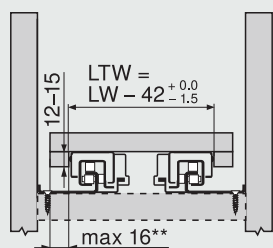
Planiranje - policia
Potreban prostor u korpusu

Izvlačenje policia

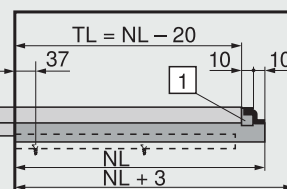
LTW Svetla tablarina širina
LW Unutrašnja širina korpusa

Izvlačenje policia

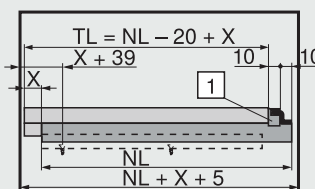
TL Dužina pregrade
NL Nominalna dužina
1 Držać za kačenje

Unutrašnje police na izvlačenju

TL Dužina pregrade
NL Nominalna dužina
1 Držać za kačenje

BLUM KLIZAČ ZA RADNE POVRŠINE

PROIZVOD



OPIS

- Mehanizam za MOVENTO i TANDEM klizače sa potpunim izvlačenjem
- BLUMOTION, TIP-ON BLUMOTION
- Preko sinhronizacije deblokiranje jednom rukom
- Primenljivo u svim stambenim zonama
- Sigurno zadržavanje
- Jednostavna i laka montaža
- Jednostavno rukovanje i sigurno oslanjanje

POTREBAN PROSTOR

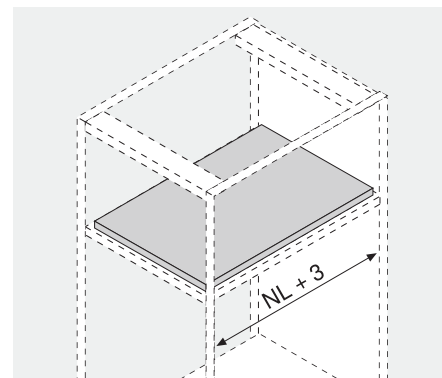

NL Nominalna dužina

1. BLOKIRANJE ZA TANDEM I MOVENTO

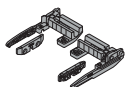

Naziv artikla	Šifra
BLOKIRANJE ZA KLIZAČE	B-295H7500

2. OSOVINA ZA SINHRONIZACIJU

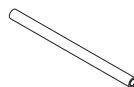

Naziv artikla	Šifra
OSOVINA ZA SINHRO. L-1160mm	B-ZST.1160W

Obrada polica na izvlačenje

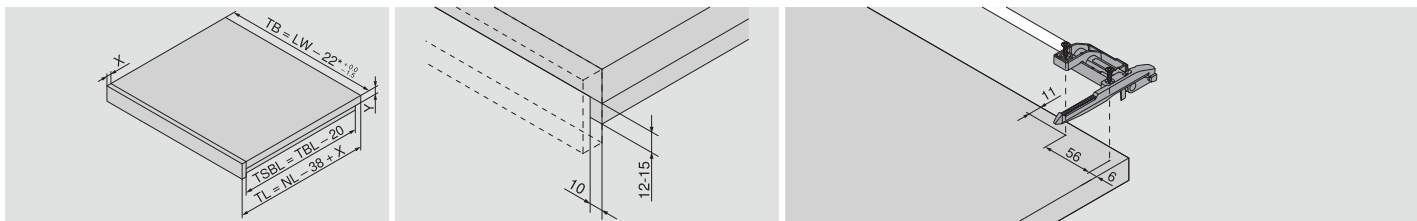

MOVENTO 760H | 766H

Potreban prostor u korpusu	Izvlačenje polica	Izvlačenje polica	Unutrašnje police na izvlačenje
* + 1 mm kod montaže korpusne šine pre sastavljanja korpusa	Ograničeno podešavanje stranica	* Dodatno +12 mm bočna stabilizacija	* Dodatnih +4mm sa TIP-ON ili dodatnim podešavanjem +3mm

TANDEM 560H | 566H

Potreban prostor u korpusu	Izvlačenje polica	Izvlačenje polica	Unutrašnje police na izvlačenje
* + 1mm sa TIP-On ili + 3mm bočne stabilizacije		* Dodatno +12 mm bočna stabilizacija	* Dodatnih +4mm sa TIP-ON ili dodatnih +2mm sa POSISTOP-om

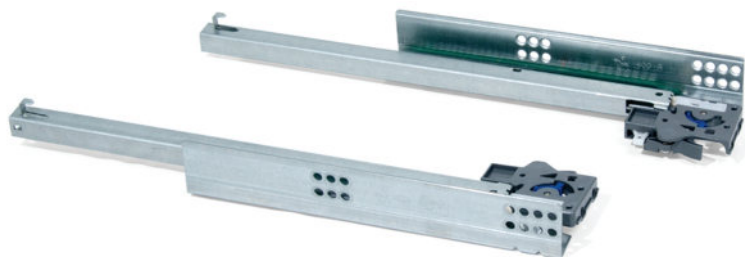
EMUCA
EMUCA SKRIVENI KLIZAČI DELIMIČNA IZVLAKA SLOW
PROIZVOD

OPIS

- Skriveni klizač delimična izvlaka
- Nosivost 25 kg
- Brza montaža i demontaža
- Podešavanje visine +3mm
- Set uključuje komplet klizača i spojki

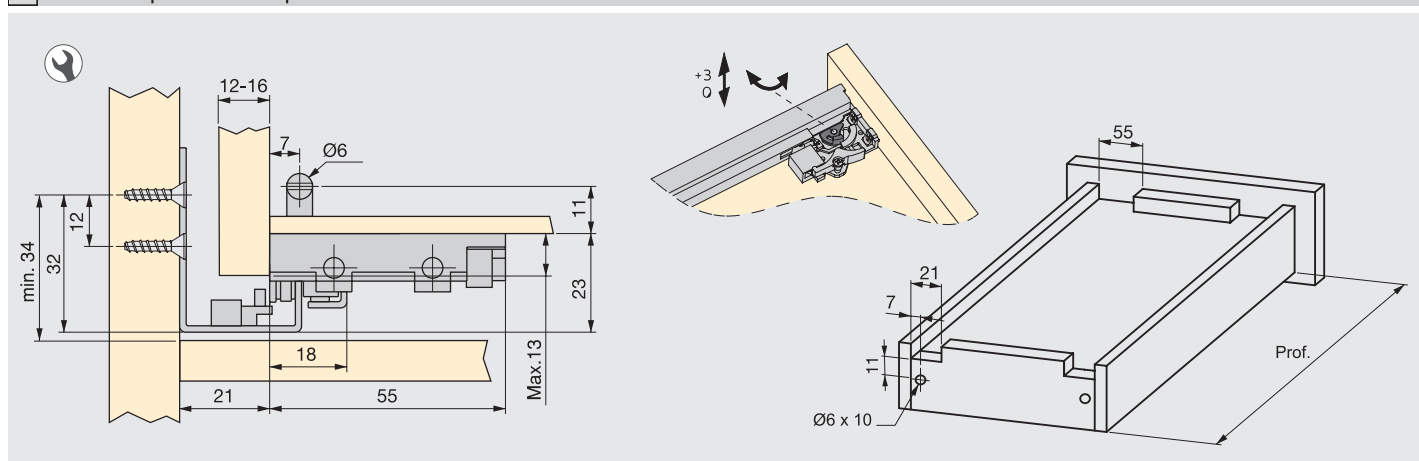
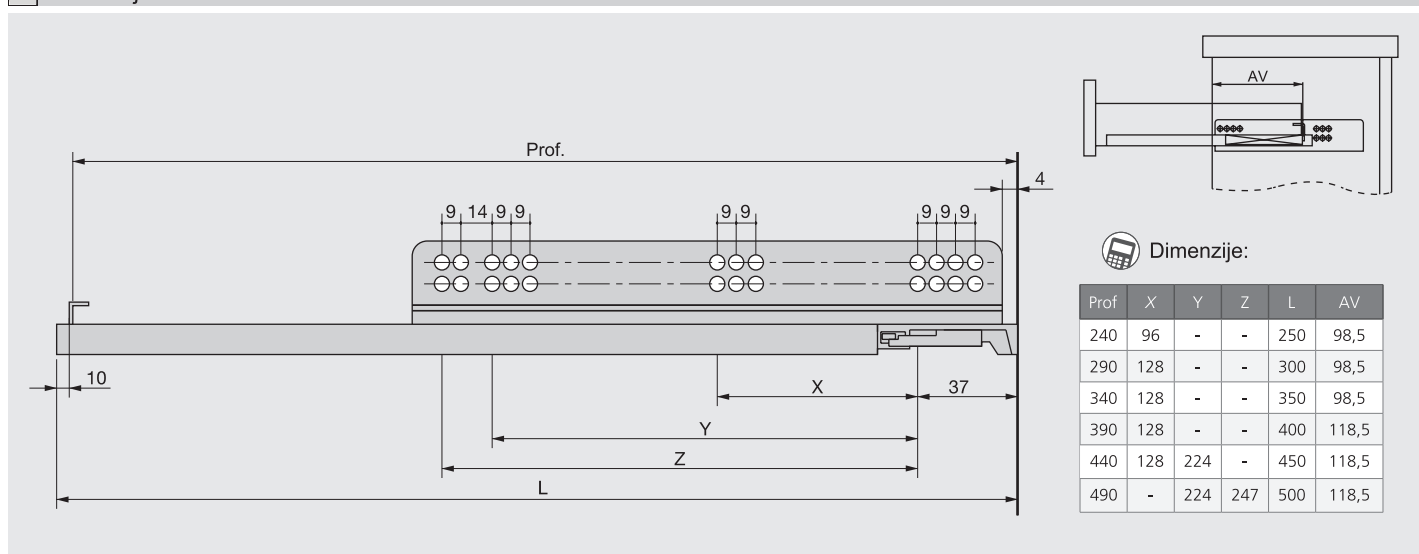

Naziv artikla	Šifra
EMUCA SKRIVENI KLIZAČ DELIM.IZVLAKA L-300+SPOJKA L/D	4003205
EMUCA SKRIVENI KLIZAČ DELIM.IZVLAKA L-350+SPOJKA L/D	4003305
EMUCA SKRIVENI KLIZAČ DELIM.IZVLAKA L-400+SPOJKA L/D	4003405
EMUCA SKRIVENI KLIZAČ DELIM.IZVLAKA L-450+SPOJKA L/D	4003505
EMUCA SKRIVENI KLIZAČ DELIM.IZVLAKA L-500+SPOJKA L/D	4003605

Potreban prostor u korpusu

Planiranje i montaža

EMUCA SKRIVENI KLIZAČI POTPUNA IZVLAKA TIP ON

PROIZVOD



emuca

OPIS

- Potpuna izvlaka sa „push“ mehanizmom
- Nosivost 25 kg
- Brza montaža i demontaža
- Podešavanje visine +4,5mm
- Set uključuje komplet klizača

Naziv artikla	Šifra
EMUCA SKRIVENI KLIZAČ PUSH POTP.IZVLAKA L-250	3002005
EMUCA SKRIVENI KLIZAČ PUSH POTP.IZVLAKA L-300	3002105
EMUCA SKRIVENI KLIZAČ PUSH POTP.IZVLAKA L-350	3002205
EMUCA SKRIVENI KLIZAČ PUSH POTP.IZVLAKA L-400	3002305
EMUCA SKRIVENI KLIZAČ PUSH POTP.IZVLAKA L-450	3002405
EMUCA SKRIVENI KLIZAČ PUSH POTP.IZVLAKA L-500	3002505

Potreban prostor u korpusu i planiranje

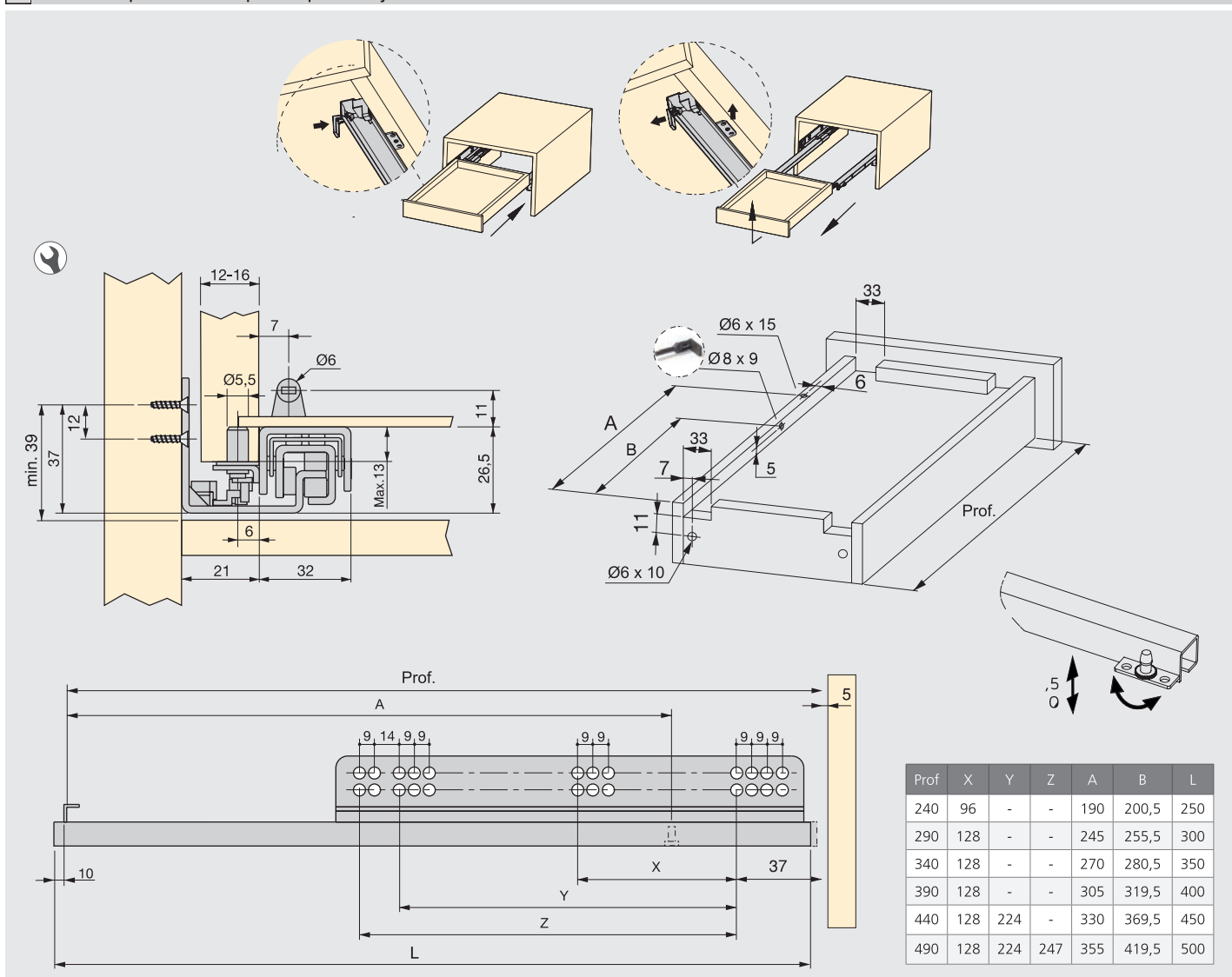

EMUCA SILVER KLIZAČI DELIMIČNA IZVLAKA
PROIZVOD

emuca

OPIS

- Skriveni klizač delimična izvlaka
- Nosivost 25 kg
- Brza montaža i demontaža
- Set uključuje komplet klizača

Naziv artikla	Šifra
EMUCA SILVER KLIZAČ DELIM.IZVLAKA L-250	3019005
EMUCA SILVER KLIZAČ DELIM.IZVLAKA L-300	3019105
EMUCA SILVER KLIZAČ DELIM.IZVLAKA L-350	3019205
EMUCA SILVER KLIZAČ DELIM.IZVLAKA L-400	3019305
EMUCA SILVER KLIZAČ DELIM.IZVLAKA L-450	3019405
EMUCA SILVER KLIZAČ DELIM.IZVLAKA L-500	3019505

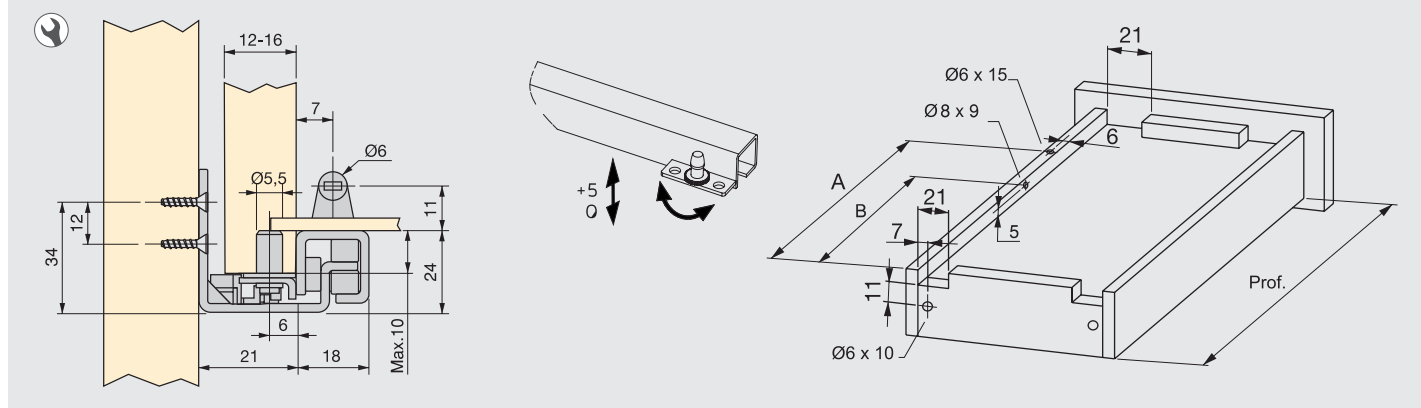
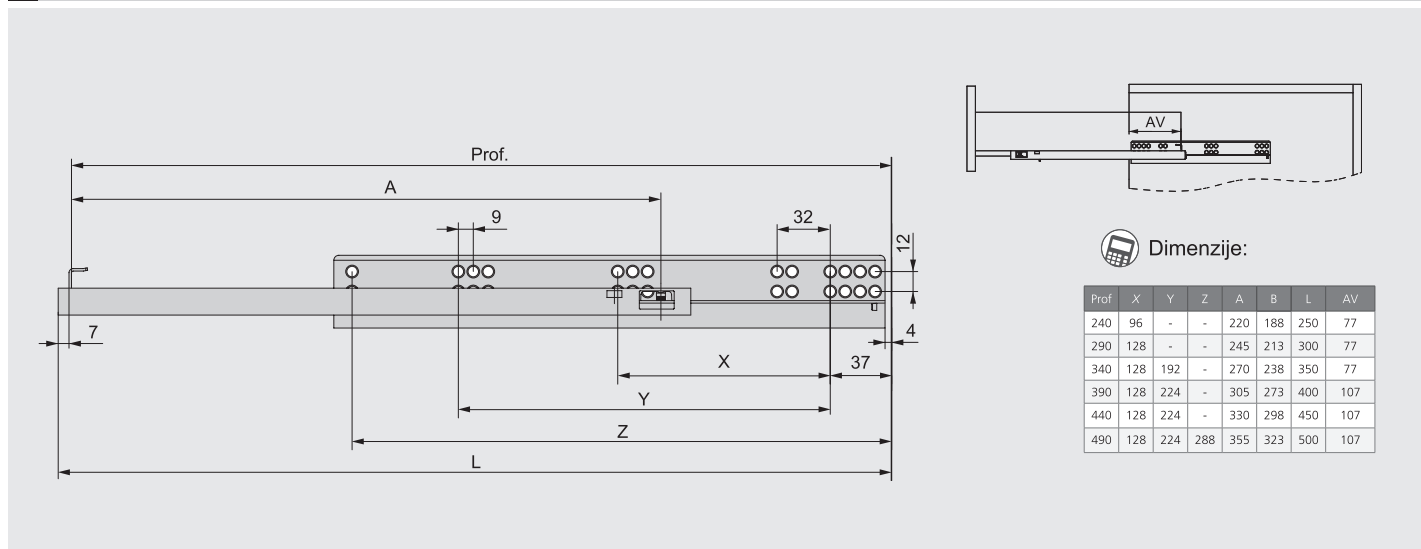
Planiranje i montaža

Planiranje i montaža

Dimenzije:

Prof	X	Y	Z	A	B	L	AV
240	96	-	-	220	188	250	77
290	128	-	-	245	213	300	77
340	128	192	-	270	238	350	77
390	128	224	-	305	273	400	107
440	128	224	-	330	298	450	107
490	128	224	288	355	323	500	107

STANDARDNI KLIZAČI

FGV KLIZAČI



Naziv artikla	Šifra
KLIZAČ FGV L-250 MM BELI	420-006
KLIZAČ FGV L-300 MM BELI	420-007
KLIZAČ FGV L-350 MM BELI	420-008
KLIZAČ FGV L-400 MM BELI	420-009
KLIZAČ FGV L-450 MM BELI	420-010
KLIZAČ FGV L-500 MM BELI	420-011
KLIZAČ FGV L-550 MM BELI	420-012
KLIZAČ FGV L-600 MM BELI	420-013

TIS KLIZAČI

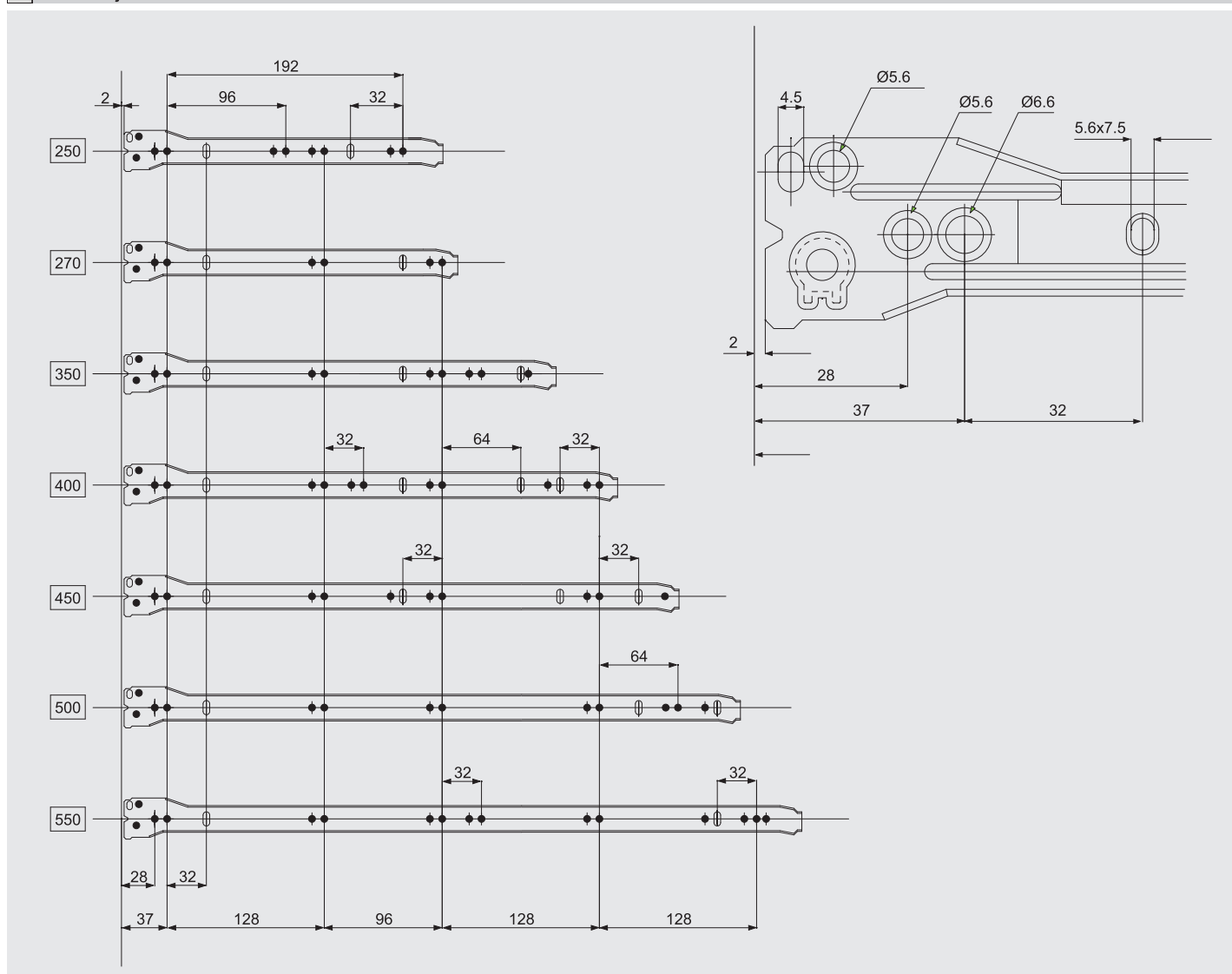

Naziv artikla	Šifra
KLIZAČ L-250 MM BELI	05.065.250.62
KLIZAČ L-300 MM BELI	05.065.300.62
KLIZAČ L-350 MM BELI	05.065.350.62
KLIZAČ L-400 MM BELI	05.065.400.62
KLIZAČ L-450 MM BELI	05.065.450.62
KLIZAČ L-500 MM BELI	05.065.500.62

 Planiranje i montaža

TELESKOPI SA AMORTIZEROM

emuca

Naziv artikla	Šifra
KLIZAČ TOT.IZ SA AMORT. L-300	4301505
KLIZAČ TOT.IZ SA AMORT. L-350	4301605
KLIZAČ TOT.IZ SA AMORT. L-400	4301705
KLIZAČ TOT.IZ SA AMORT. L-450	4301805
KLIZAČ TOT.IZ SA AMORT. L-500	4301905
KLIZAČ TOT.IZ SA AMORT. L-550	4302005
KLIZAČ TOT.IZ SA AMORT. L-600	4302105
KLIZAČ TOT.IZ SA AMORT. L-650	4302205

Planiranje i montaža

L	X	Y	A	B	C
300	121,5	80	96	-	-
350	122	128	72,5	55,5	-
400	160	128	128	55,5	-
450	160	160	128	96	-
500	192	192	128	96	64
550	224	224	128	96	96
600	256	256	128	96	128
650	256	256	128	96	128

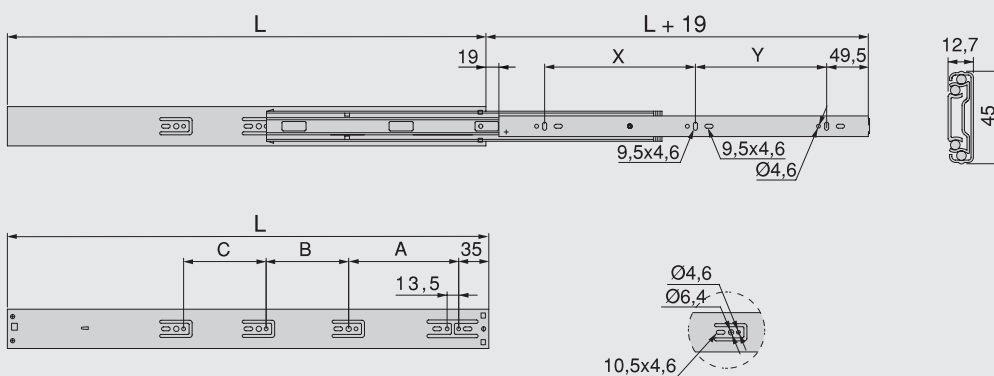
TELESKOPI

Naziv artikla	Šifra
KLIZAČ TOT. IZVLAČENJE L-250	08.091.B25.05
KLIZAČ TOT. IZVLAČENJE L-300	08.091.B30.05
KLIZAČ TOT. IZVLAČENJE L-350	08.091.B35.05
KLIZAČ TOT. IZVLAČENJE L-400	08.091.B40.05
KLIZAČ TOT. IZVLAČENJE L-450	08.091.B45.05
KLIZAČ TOT. IZVLAČENJE L-500	08.091.B50.05
KLIZAČ TOT. IZVLAČENJE L-550	08.091.B55.05
KLIZAČ TOT. IZVLAČENJE L-600	08.091.B60.05
KLIZAČ TOT. IZVLAČENJE L-650	08.091.B65.05
KLIZAČ TOT. IZVLAČENJE L-700	08.091.B70.05
KLIZAČ TOT. IZVLAČENJE L-800	08.091.B80.05
KLIZAČ TOT. IZVLAČENJE L-900	08.091.B90.05

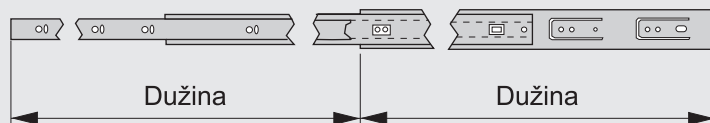
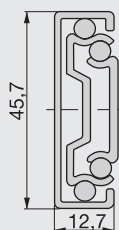
Planiranje i montaža

MIKROKLIZAČI



Naziv artikla	Šifra
MIKROKLIZAČ EMUCA 17/214	4207205
MIKROKLIZAČ EMUCA 17X278	4207405
MIKROKLIZAČ EMUCA 17X310	4207505
MIKROKLIZAČ EMUCA 17X342	4207605

Planiranje i montaža

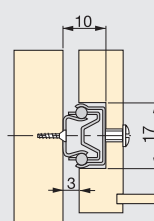
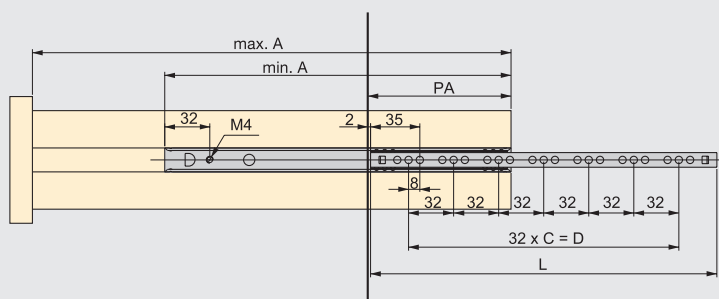

Dimenzije:

Cod.	C	D	L
42072 05	5	160	214
42074 05	7	224	278
42075 05	8	256	310
42076 05	9	288	342



